



Gas Appliance Pressure Regulators

Straight-Thru-Flow Design

RV52, RV53, RV61, RV81, RV91, RV111, and RV131
1/2", 3/4", 1", 1¼", 1½", 2", 2½", 3" & 4"



design certified

Maximum Pressure

CSA Rated (except RV131) 1/2 psi (35 mbar)

Maxitrol Tested*

RV52 & RV53 1/2 psi (35 mbar)

RV61, RV81, RV91, & RV111 1 psi (70 mbar)

RV131 2 psi (140 mbar)

* Do not use if inlet pressure is more than 10 times desired outlet pressure

EMERGENCY EXPOSURE LIMITS (Maxitrol Tested)

RV52 & RV53 3 psi (210 mbar)

RV61, RV81, RV91 & RV111 5 psi (350 mbar)

RV131 15 psi (1050 mbar)

GAS CONTAINMENT EXPOSURE LIMITS*

RV 52 & RV53 15 psi (1050 mbar)

RV61, RV81, RV91, RV111,

& RV131 25 psi (1750 mbar)

* Please note that internal damage may occur when exposed to these pressures.

AMBIENT TEMPERATURE LIMITS

RV52, RV53, RV61, RV81,

RV91 & RV111 -40° to 205° F (-40° to 96° C)

RV131 -40 to 125° F (-40 to 52° C)

GASES: Natural, manufactured, mixed, liquefied petroleum, or LP gas-air mixture.



S-T-F Series



Straight-Thru-Flow Design

RV series

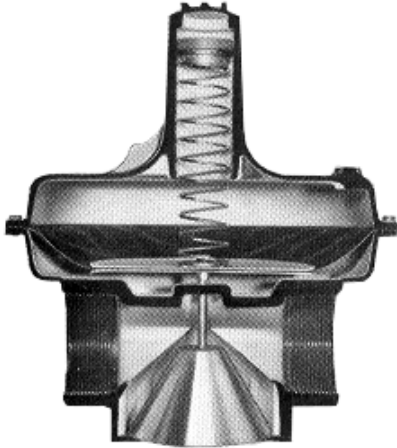

**RV52, RV53, RV61, RV81,
RV91, RV111, and RV131**

FEATURES

- Greater accuracy—higher pressure drop capacity
- Outlet pressures available to 42" w.c.
- Available in full range of pipe sizes from 1/2" to 4"
- All models tapped with NPT vent bosses
- CSA Design Certified (except RV131)

BENEFITS

- Unique conical valve design fills need of combining good regulation with high capacity in low to intermediate pressure range
- Allows more pressure drop to be assigned to piping and valves—permits reduction in manifold size
- Provides accurate, sensitive regulation at inlet pressures as low as 3" w.c.
- RV131 only, provides bonus benefits of high capacity and good performance at pressures of 1 psi or higher
- Ease of installation and replacement

All models except RV131 are CSA design certified for 1/2 psi rated pressure under the ANSI standard for gas pressure regulators; and CSA listed to certify compliance with nationally published safety, construction, and performance standards.

They are main burner only, non-lockup type. They should not be used as a line gas pressure regulator ahead of low pressure controls. Use only where downstream controls can operate at line pressure. Refer to other Maxitrol sales bulletins for proper types.

The RV52, RV53, & RV61 are suitable for multipoise mounting. The RV81, RV91, RV111, & RV131 are recommended for normal horizontal position only.

Maxitrol's original Straight-Thru-Flow design meets your needs for high capacities at low inlet pressures. The basic difference between S-T-F design and other type regulators lies in the conical valve. The cone principal permits gas to flow straight through the regulator without changing directions. Frictional flow resistance is reduced, resulting in greater capacity.

The improved flow pattern provides accurate sensitive regulation at extremely low pressure differentials. The ability of the regulator to handle large capacity appliances with limited supply pressure offers a definite advantage to designers of commercial and industrial gas-fired equipment. Models up to the three inch pipe size have high strength pressure cast aluminum housings. The

RV131 four inch model is of cast iron and steel construction. RV61, RV81, RV91, RV111, & RV131 internal conical valves are coated with Teflon® for long life. Diaphragm material is cut from the finest synthetic coated fabrics available. All other parts are carefully specified corrosion-resistant or plated material.

Pipe sizes of 1/2", 3/4", 1", 1-1/4", 1-1/2", 2", 2-1/2", 3", and 4" are available. Models through the 3" size are threaded, the 4" RV131 is flanged.

At the emergency exposure limits, there may be no regulation, but all models will contain gas. They will suffer no internal damage and will resume regulation when normal pressure is restored.

Straight-Thru-Flow appliance regulators are intended for use with all fuel gases, and may also be used with air or other noncorrosive gases within their pressure limits.

Typical applications include all types of residential, commercial and industrial gas-fired appliances and equipment used on low pressure gas supply. See Maxitrol's "Spring Selection Chart" for part numbers, color and size of springs.

Teflon is a registered trademark of DuPont Corporation.

NOTE: All Maxitrol appliance regulators should be installed in accordance with Maxitrol's "Safety Warning" bulletin.

Capacities and Pressure Drop

CAPACITIES—expressed in CFH (m³/h)—0.64 sp gr gas

Model Number and Pipe Size		CSA MAX	Pressure Drop Inches w.c. (mbar)												
			0.1	0.2	0.3	0.4	0.5	0.6	0.7	0.8	0.9	1	2	3	4
RV52	1/2 x 1/2 3/4 x 3/4	450 (12.7)	151 (4.2)	214 (6.1)	262 (7.4)	302 (8.5)	338 (9.5)	370 (10.5)	400 (11.3)	427 (12.1)	453 (12.8)	478 (13.5)	676 (19.1)	828 (23.4)	956 (27.1)
RV53	3/4 x 3/4 1 x 1	710 (20.1)	217 (6.1)	306 (8.6)	375 (10.6)	433 (12.2)	484 (13.7)	530 (15)	573 (16.2)	612 (17.3)	650 (18.4)	684 (19.3)	968 (27.4)	1185 (33.5)	1369 (38.7)
RV61	1 x 1 1-1/4 x 1-1/4	1100 (31.1)	379 (10.7)	536 (15.1)	675 (19.1)	759 (21.5)	848 (24)	929 (26.3)	1004 (28.4)	1073 (30.4)	1138 (32.2)	1200 (34.0)	1742 (49.3)	2134 (60.4)	2464 (69.8)
RV81	1-1/4 x 1-1/4 1-1/2 x 1-1/2	2500 (70.8)	780 (22.1)	1102 (31.2)	1350 (38.2)	1559 (44.1)	1743 (49.5)	1909 (54)	2062 (58.4)	2204 (62.4)	2339 (66.2)	2465 (69.8)	3485 (98.7)	4269 (120)	4929 (139)
RV91	2 x 2 2-1/2 x 2-1/2	3275 (92.7)	1212 (34.3)	1714 (48.5)	2100 (59.4)	2424 (68.6)	2711 (76.7)	2969 (84.1)	3208 (90.8)	3429 (97.1)	3637 (103)	3834 (108)	5422 (153)	6640 (188)	7668 (217)
RV111	2-1/2 x 2-1/2 3 x 3	7500 (212)	2742 (78)	3878 (110)	4750 (134)	5485 (155)	6132 (175)	6718 (190)	7256 (205)	7757 (219)	8227 (233)	8572 (243)	12134 (343)	14862 (420)	17161 (486)
RV131	4 x 4	--	4734 (134)	6695 (190)	8200 (232)	9468 (268)	10586 (300)	11596 (328)	12525 (354)	13390 (380)	14202 (402)	14971 (424)	21172 (600)	25930 (734)	29942 (848)

Sizing Instructions

In order to select the proper size regulator, you must know the available inlet pressure, desired outlet pressure, and the required maximum flow rate.

Example No. 1—To select a regulator of ample capacity to handle flow.

KNOWN:

Pipe size 2-1/2", flow rate 8,000 CFH (0.64 sp gr), inlet pressure 9" w.c., desired outlet pressure 5" w.c.

SOLUTION:

- Determine differential pressure available:
 Inlet pressure 9" w.c.
 Subtract outlet pressure - 5" w.c.
 Available differential pressure 4" w.c.
- When determining capacity Maxitrol recommends that the pressure drop not exceed 1/2 of available differential pressure (1/2 of 4" w.c. = 2" w.c.).
- Check Capacity Chart to determine which regulator has a pressure drop of 2" w.c. or less at a flow rate of 8,000 CFH.
- The RV111 meets these standards with a flow rate of 12,134 CFH for the 2-1/2" pipe size at 2" w.c. pressure drop. The 2-1/2" RV91 flows 5422 CFH at 2" w.c. pressure drop. Therefore, the RV111—2-1/2" is the correct regulator to use.

Example No. 2—To determine maximum recommended operating outlet pressure.

KNOWN:

Pipe size 4", flow rate 21,000 CFH, inlet pressure 10" w.c.

SOLUTION:

- Check capacity Chart above for 4" regulator, RV131.
- Note that at a flow rate of 21,172 CFH the pressure drop is 2" w.c.
- Multiply this by two to obtain recommended differential pressure (4" w.c.).
- Subtract 4" differential pressure from 10" w.c. inlet pressure to obtain maximum recommended outlet pressure setting of 6" w.c.

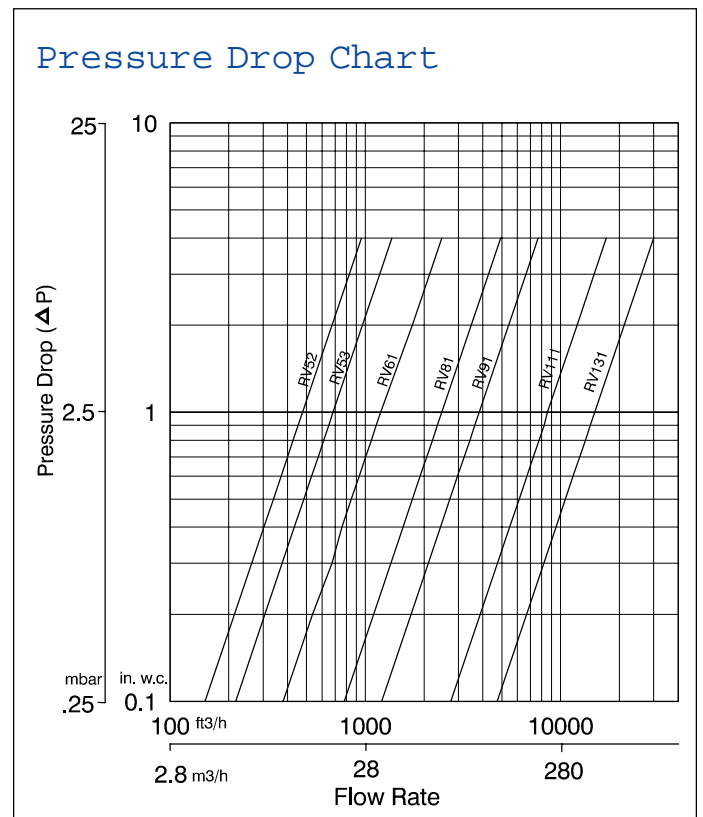

Dimensions and Spring Ranges

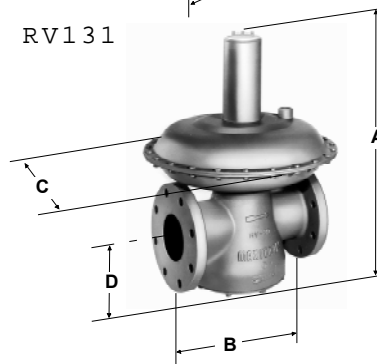
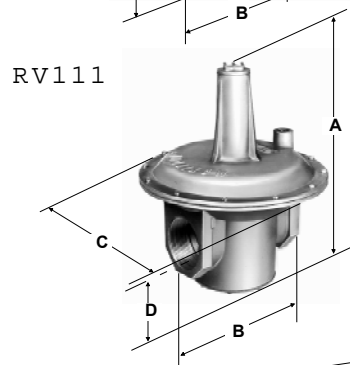
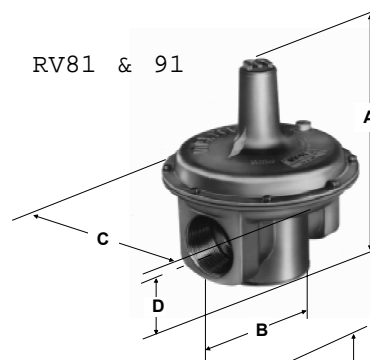
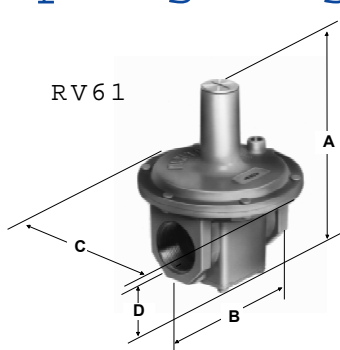
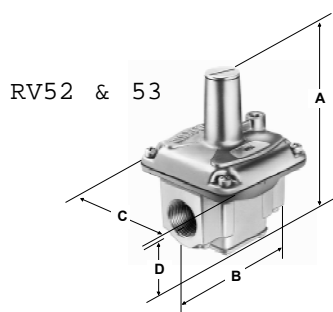

DIMENSIONS*—inches (millimeters)

Model & Illustration Number	Vent Tap	Swing Radius	Call-Outs			
			A	B	C	D
RV52	1/8" NPT	3.6 (91)	4.9 (124)	3.2 (81)	3.25 (83)	1.25 (32)
RV53	1/8" NPT	3.9 (99)	5.2 (132)	3.75 (95)	3.9 (99)	1.3 (33)
RV61	1/8" NPT	4.8 (122)	6.4 (164)	4.4 (111)	5.4 (138)	1.6 (41)
RV81	3/8" NPT	6.4 (162)	8.4 (213)	6 (153)	7 (178)	2 (51)
RV91 2" pipe	1/2" NPT	8.5 (216)	10.8 (275)	6.5 (165)	9.1 (232)	2.3 (60)
RV91 2.5" pipe	1/4" NPT	8.3 (212)	10.5 (267)	7.1 (181)	9.1 (232)	2.4 (62)
RV111	3/4" NPT	11.5 (284)	15.1 (373)	9 (229)	13.4 (324)	3.5 (89)
RV131	3/4" NPT	18.2 (462)	23.25 (590)	13.9 (353)	18 (458)	5.1 (129)

* Dimensions are to be used only as an aid in designing clearance for the valve. Actual production dimensions may vary somewhat from those shown.

SPRING SELECTION CHART—inches w.c. (mbar)

Model Number	CSA Certified Springs			Other Springs Available							
	3 to 6 (7.5-15)	4-8 (10-20)	5-12 (12.5-30)	1-3.5 (2.5-9)	2-5 (5-12.5)	3-8 (7.5-20)	4-12 (10-30)	--	--	--	--
RV52	3 to 6 (7.5-15)	4-8 (10-20)	5-12 (12.5-30)	1-3.5 (2.5-9)	2-5 (5-12.5)	3-8 (7.5-20)	4-12 (10-30)	--	--	--	--
RV53	3 to 6 (7.5-15)	4-8 (10-20)	5-12 (12.5-30)	1-3.5 (2.5-9)	2-5 (5-12.5)	3-8 (7.5-20)	4-12 (10-30)	--	--	--	--
RV61	3 to 6 (7.5-15)	4-8 (10-20)	5-12 (12.5-30)	1-3.5 (2.5-9)	2-5 (5-12.5)	3-8 (7.5-20)	--	--	10-22 (25-55)	--	--
RV81	3 to 6 (7.5-15)	4-8 (10-20)	5-12 (12.5-30)	1-3.5 (2.5-9)	2-5 (5-12.5)	3-8 (7.5-20)	4-12 (10-30)	5-15 (12.5-38)	10-22 (25-55)	--	--
RV91	3 to 6 (7.5-15)	4-8 (10-20)	5-12 (12.5-30)	1-3.5 (2.5-9)	2-5 (5-12.5)	3-8 (7.5-20)	4-12 (10-30)	5-15 (12.5-38)	10-22 (25-55)	--	--
RV111	3 to 6 (7.5-15)	4-8 (10-20)	5-12 (12.5-30)	1-3.5 (2.5-9)	2-5 (5-12.5)	3-8 (7.5-20)	4-12 (10-30)	5-15 (12.5-38)	10-22 (25-55)	--	--
RV131	3 to 6 (7.5-15)	--	5-12 (12.5-30)	--	2-5 (5-12.5)	3-8 (7.5-20)	4-12 (10-30)	--	10-22 (25-55)	15-30 (38-75)	20-42 (50-105)

NOTE: The area within the heavy line indicates CSA certified springs.

A copyrighted publication of

MAXITROL®  **company**

www.maxitrol.com

Maxitrol Company
23555 Telegraph Rd., P.O. Box 2230
Southfield, MI 48037-2230 U.S.A.
248.356.1400 • Fax 248.356.0829

European Representatives
Warnstedter Strasse 3 06502 Thale, Germany
49.3947.400.0 • Fax 49.3947.400.200
Industriestrasse 1 48308 Senden, Germany
49.2597.9632.0 • Fax 49.2597.9632.99