

SERIES 35-63



24 VAC Microprocessor Based Intermittent Pilot Ignition Control

35.63.01

FEATURES

- System diagnostic LED
- Automatic reset 1 hour after lockout option
- Safe Start and full time flame sensing
- Remote flame sense option
- Flame sense test pins
- Custom prepurge and interpurge timings
- Multiple trials for ignition

APPLICATIONS

- Commercial cooking equipment
- Commercial gas furnaces
- Unit heaters
- Water heaters

DESCRIPTION

The 35-63 is a 24 VAC intermittent pilot ignition control. The microprocessor circuit design provides precise, repeatable timing and operating sequences. The on-board diagnostics with LED output provide assistance with troubleshooting to ensure safe and efficient operation.

Agency Certifications

 Component recognized system. Software conforms to UL 1998 requirements

 Design certified to ANSI Z21.20, CAN/CSA C22.2 No. 199-M99

 CE Approved to EN298 (Pending)

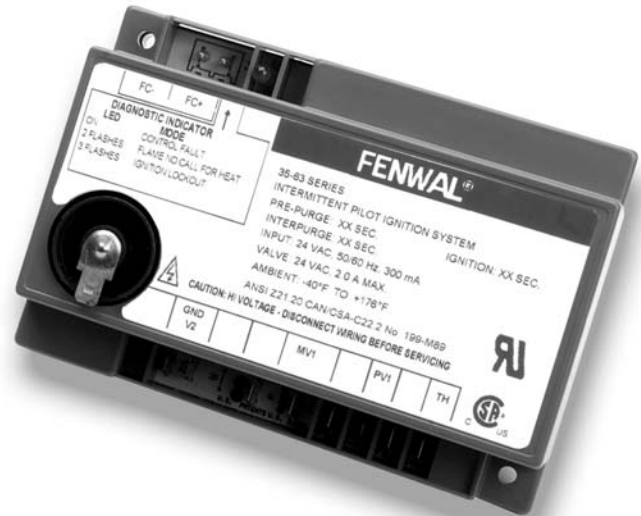

SPECIFICATIONS

Input Power	Control: 18-30 VAC 50/60 Hz (Class 2 Transformer)
Input Current Drain	300 mA @24 VAC with gas and pilot relays energized (Control only)
Main Gas Valve	2.0A max (continuous)
Pilot Gas Valve	2.0A max (continuous)
Operating Temperature	-40°F to +176°F (-40°C to +80°C)
Storage Temperature	-40°F to +185°F (-40°C to +85°C)
Flame Sensitivity	0.7 uA minimum
Flame Failure Response Time	0.8 seconds maximum
Types of Gases	Natural, LP, or manufactured
Spark Rate	Line frequency (50/60 sparks/sec)
Size (LxWxH)	5.69 x 3.94 x 1.87 inches (with cover) 14.45 x 10.0 x 4.75 cm (with cover)
Weight	8 ounces (nominal) 224 grams (nominal)
Moisture Resistance	Conformal coated to operate non-condensing to 95% R.H. Care must be taken to protect module from direct exposure to water
Tries for Ignition	One or three try versions available
Trial for Ignition Periods	15, 30, 60, 90 seconds available
Prepurge Timings	None, 15, 30 45 seconds available
Interpurge Timings	None, 15, 30 seconds, or 4 minutes available

SEQUENCE OF OPERATION / FLAME RECOVERY / SAFETY LOCKOUT

Start Up - Heat Mode

When a call for heat is received from the thermostat supplying 24 volts to TH/W, the control will reset, perform a self check routine, flash the diagnostic LED once in the first two seconds, and a pre-purge delay begins. Following the pre-purge period, the pilot gas valve is energized and sparks commence for the trial for ignition period. The main gas valve is de-energized until the pilot flame is detected.

When the pilot flame is detected during the trial for ignition, the sparking process is shutoff immediately and the main gas valve is energized. The thermostat and pilot burner flame are constantly monitored to assure the system continues to operate properly. When the thermostat is satisfied and the demand for heat ends, the pilot and main valves are de-energized immediately.

Failure to Light - Lockout

SINGLE TRIAL MODEL

Should the pilot burner fail to light or the pilot flame is not detected during the trial for ignition period, the control will go into lockout. The valves are de-energized immediately. The LED will indicate the code for ignition lockout.

MULTI TRIAL MODEL

Should the pilot burner fail to light, or pilot flame is not detected during the first trial for ignition period, the pilot and main gas valves are de-energized. The control then goes through an inter-purge delay before another ignition attempt. The control will attempt two additional ignition trials before going into lockout and the valve relays will be de-energized immediately. Recovery from lockout requires a manual reset by either resetting the thermostat or removing 24 volts for a period of 5 seconds. On models with automatic reset, if the thermostat is still calling for heat after one hour the control will automatically reset and attempt to ignite the burner.

FLAME FAILURE- RE-IGNITION MODE

If the established pilot flame signal is lost while the burner is operating, the control will respond within 1 second by de-energizing the main gas valve and energizing the HV spark in an attempt to relight the pilot burner for the programmed TFI period. If the pilot burner does not light within the TFI, the pilot gas valve is de-energized immediately and on multi-try models a new TFI sequence begins. If the pilot burner does not relight, the control will lockout as previously described in the "Failure to Light - Lockout" section. Multi-try models will make 2 more attempts to light the burner. If pilot flame is re-established, normal operation resumes.

FLAME FAILURE- RECYCLE MODE

The option "recycle after loss of flame" may be selected as a special feature. With this option, upon loss of pilot flame, gas valves are de-energized and the controller proceeds to inter-purge before attempting to relight the pilot flame. Multi-try models will allow three tries for ignition including inter-purges. If pilot burner relights, normal operation resumes, if pilot burner does not relight, control will go into lockout as described in "failure to light".

TABLE 1 - FAULT CONDITIONS

LED INDICATION	FAULT MODE
2 Flashes	Pilot flame without call for heat
3 Flashes	Ignition Lockout
Steady On	Internal Control Failure

The LED will flash on for 1/4 second, then off for 1/4 second during a fault condition. The pause between fault codes is 3 seconds.

Internal Control Failure:

If the control detects an error in its software or hardware, all outputs are turned off and the LED displays a steady ON condition.

MOUNTING AND WIRING

The Series 35-63 is not position sensitive and can be mounted vertically or horizontally. The case may be mounted on any surface with #6 sheet metal screws.



WARNING:

All wiring must be done in accordance with both local and national electrical code.



WARNING:

The Series 35-63 uses voltages of shock hazard potential. Wiring and initial operation must be done by a qualified service technician.

TABLE 2 - WIRING TERMINALS

TERMINAL	DESCRIPTION	QUICK CONNECT
TH/W	Thermostat Input	1/4 inch
PV1	Pilot Valve Power	3/16 inch
MV1	Main Valve Power	1/4 inch
V2	Valve Ground	3/16 inch
GND	System Ground	3/16 inch
S1	Remote Flame Sensor (Optional)	1/4 inch
HV	High Voltage Output	1/4 inch



CAUTIONS:

Label all wires prior to disconnection when servicing controls. Wiring errors can cause improper and dangerous operation. A functional checkout of a replacement control is recommended.



WARNING:

Operation outside specifications could result in failure of the Fenwal product and other equipment with injury to people and property

LOCAL SENSE

Figure 1

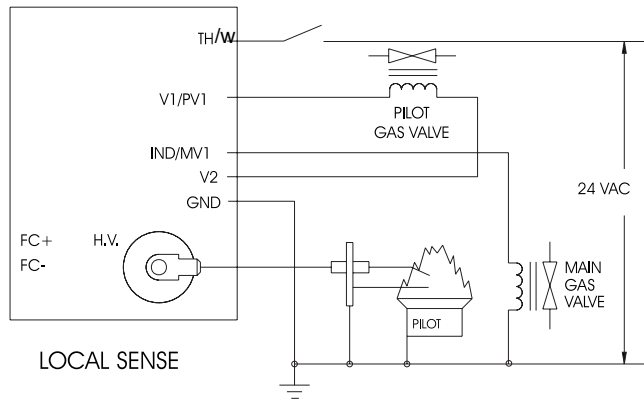

LOCAL SENSE

REMOTE SENSE

Figure 2

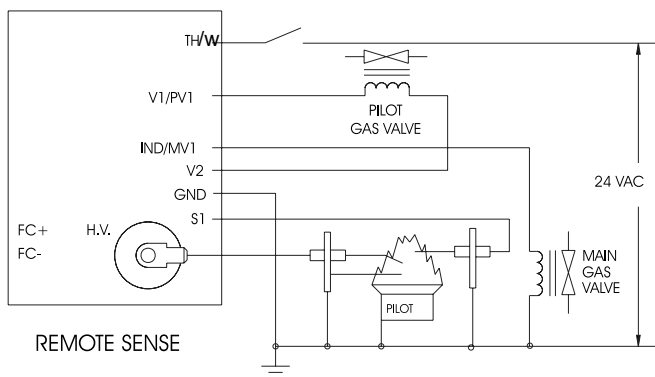

REMOTE SENSE

Proper Electrode Location

Proper location of the electrode assembly is important for optimum system performance. It is recommended that electrode assembly be mounted temporarily using clamps or other suitable means so that the system can be checked before permanently mounting the assembly. The electrode assembly should be located so that the tips are inside the flame envelope and about 1/2 inch (1 cm) above the base of the flame. See Figure 3 below.

Figure 3

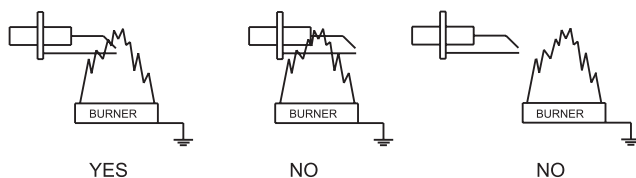

CAUTIONS:

1. Ceramic insulators should not be in or close to the flame.
2. Electrode assemblies should not be adjusted or disassembled. Electrodes should have a gap spacing of 0.125 ± 0.031 in (3.12 ± 0.81 mm), unless otherwise specified by the appliance manufacturer. If this spacing is not correct, the assembly must be replaced. Electrodes are NOT field adjustable.
3. Exceeding the temperature limits can cause nuisance lockouts and premature electrode failure.
4. Electrodes must be placed where they could not be exposed to the appliance user in normal operation.

TABLE 3 - TROUBLESHOOTING GUIDE

SYMPTOM	RECOMMENDED ACTIONS
1. Control does not start	A. Miswired B. 24 VAC Transformer bad C. Fuse/Circuit breaker bad D. Bad control, check LED for steady on or flashing code (see Table 1)
2. Thermostat on - no spark	A. Miswired B. Bad thermostat, no voltage at thermostat terminal W C. Bad control, check LED for steady on or flashing codes
3. Valve on - no spark during TFI	A. Shorted electrode - establish 1/8th inch gap B. Check high voltage cable C. Miswired
4. Spark on - valve off	A. Valve coil open B. Valve wire disconnected C. Bad control, check voltage at gas valve terminals PV1 or MV1 and V2
5. Flame okay during TFI - no flame sense after TFI	A. Check electrode position B. Check high voltage wire C. Poor ground at burner D. Poor flame, check flame current

Flame Sensor Current Check

Flame current is the current that passes through the flame from the sensor to ground. The minimum flame current necessary to keep the system from lockout is 0.7 micro amps. To measure flame current, connect analog DC microammeter to the FC-, FC+ terminals per figure. Meter should read 0.7 microamps or higher. If the meter reads below "0" on scale, meter leads are reversed. Disconnect power and reconnect meter leads for proper polarity.

Figure 4

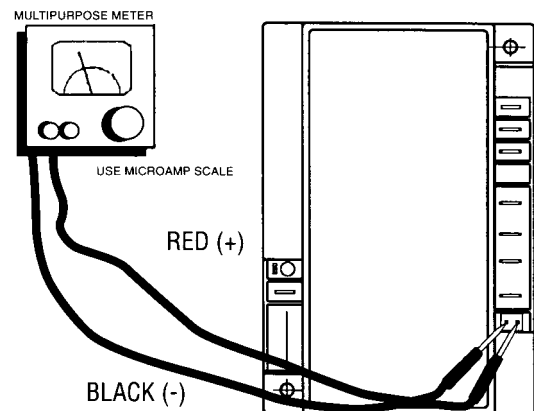

CONTROL CONFIGURATION

35 - 63 0 XXX - XXX

Options

- 1 = Recycle after Loss of Flame
- 5 = Re-ignition after Loss of Flame
- 9 = Special OEM Configuration

Enclosure Configurations and Wiring Options

- 0 = Noryl Gray Enclosure
- 1 = Integral Standoffs
- 2 = Board Only

Pre-Purge Time

- 0 = None
- 1 = 15 seconds
- 2 = 30 seconds
- 3 = 45 seconds
- 4 = 4 minutes

Inter-Purge Time

- 0 = None (Single Try Models Only)
- 1 = 15 seconds
- 2 = 30 seconds
- 3 = 45 seconds
- 4 = 4 minutes

Trial for Ignition Time (TFI)

- 1 = 15 seconds
- 3 = 30 seconds
- 5 = 60 seconds
- 7 = 90 seconds

Number of Ignition Trials, Flame Sense Method and Lock Out Reset Method

- | | |
|-------------------------------|------------------------------|
| 0 = Single Try, Local Sense | Thermostat / power off reset |
| 1 = Single Try, Remote Sense | Thermostat / power off reset |
| 2 = Single Try, Local Sense | Automatic Reset |
| 3 = Single Try, Remote Sense | Automatic Reset |
| 5 = Three Tries, Local Sense | Thermostat / power off reset |
| 6 = Three Tries, Remote Sense | Thermostat / power off reset |
| 7 = Three Tries, Local Sense | Automatic Reset |
| 8 = Three Tries, Remote Sense | Automatic Reset |

DIMENSIONS

Figure 5:
Uncovered
with standoffs

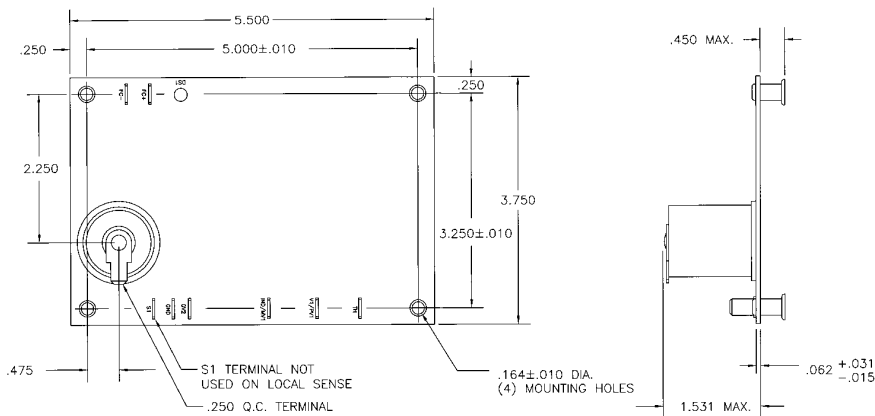
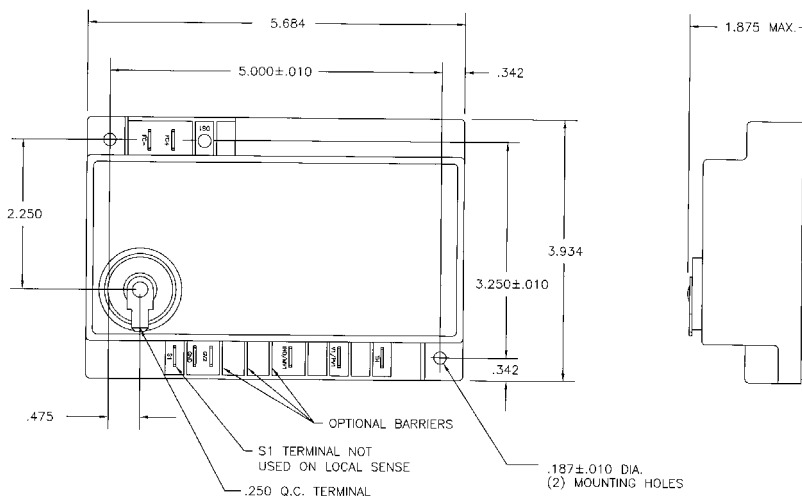

Figure 6:
With cover



FENWAL
400 MAIN STREET, ASHLAND, MA 01721
TEL: (508) 881-2000 FAX: (508) 881-6729
www.fenwalcontrols.com

These instructions do not purport to cover all the details or variations in the equipment described, nor do they provide for every possible contingency to be met in connection with installation, operation and maintenance. All specifications subject to change without notice. Should further information be desired or should particular problems arise which are not covered sufficiently for the purchaser's purposes, the matter should be referred to KIDDE-FENWAL, Inc., Ashland, Massachusetts.